

Easylon® Interfaces

Connecting to LONWORKS® and

CEA-709.1 Networks

Interfaces+

High performance network access

Remote Access Solutions

IP network access

PC/104 and Socket Interfaces

The OEM solutions



Easylon® Interfaces

Connecting to LONWORKS® and CEA-709.1 Networks

A multitude of Easylon products is designated to access the data of LONWORKS or CEA-709.1 compatible networks for distributed, intelligent automation; especially the Easylon interfaces and Easylon software, such as the OPC servers or the RNI capability of the Easylon interfaces.

Design and scope of performance of the Easylon interfaces are designated to the highest demands. We attach great importance to

- ability of use, especially in industrial applications,
- support of current operating systems,
- support of current bus systems and latest technical developments,
- usability in LONWORKS networks either with or without LNS,
- the needs of users that have to access these interfaces with their own applications,
- the customers desire for products with most simple usability.

These are the reasons why each and any Easylon interface offers a variety of variants though they have a lot in common, as compiled in the following.

However, shouldn't you be able to trace the solution you are looking for – just ask us. Maybe we already realized the solution for your problem for another customer in the past or it is already under development.

LONWORKS and CEA-709.1

The ANSI/CEA-709.1 standard “Control Network Protocol Specification” describes the LonTalk® protocol underlying the LONWORKS technology. Based on this specification and licensed by Echelon Corp. network nodes can be developed independent of the NEURON Chip® otherwise mandatory. Gesytec is offering CEA-709.1 based products: the Interface⁺. The plus is indicating that there is to be expected more than from a stand LONWORKS node. The technology is as well described by the European standard EN 14908.

Interfaces⁺

Technically the “plus” products realize the control network functionality on chip different from the NEURON Chip. For the interfaces this means a separation into a physical and a logical part, also referred to as virtual network interface (VNI). With respect to a typical Easylon Interface⁺ card for a PC this means that the card implements protocol layers 1 and 2 of the interface while the PC realizes layers 3 to 7.

Several advantages arise from this:

- The performance of modern PCs and servers can be used.
- On the interface card a powerful processor and sufficient buffer can be used.
- The PC receives all messages.
- Time stamps can be set.
- The PC sends messages with any source address.
- The PC emulates several (currently up to 8) logical interfaces, each having a node-ID of its own.
- Ordinary drivers are used to access the interface.
- Several programs can access the interface hardware in parallel.
- 16 bit programs as well as 32 bit or 64 bit programs can be used.

In practice this means:

- All PC applications previously used can be used further on without modifications.
- Compatibility with Echelon interfaces.
- Parallel transactions in MIP mode.
- Up to eight applications can access the network in parallel. In addition to the normal applications network analysis and network management can be run.
- A larger number of address table entries can be used.
- There is an efficient hardware interface.
- Any Easylon Interfaces⁺ is the hardware basis for the Easylon Analyzer.



Easylon® Interfaces

General Properties

Drivers

Windows operating systems from Windows 2000 to the current ones are supported, for 32 bit and 64 bit systems. This refers as well to Windows CE. For some cards even older drivers for Windows 95 and 98, NT, ME or DOS are available. These, however, are no longer supported and are provided without warranty.

Using the drivers the user can assign driver names at will. This is as well advantageous with older systems and applications requiring a systematical naming when using several interfaces (LON1, LON2, ...) as with distributed applications, which are accessed by the driver name, e.g. accessing remote systems via RNI. Then descriptive names can be used.

Linux drivers are provided too for most of the interfaces. They come in source code for different kernel versions.

Driver updates and versions for the latest operating systems can be downloaded any time from the support pages of the Gesytec web site. If you want others than the standard, feel free to ask.

MIP or NSI Firmware

To be able to operate as a network interface the NEURON Chip requires a special firmware. Two types are available: MIP and NSI. The NSI firmware is required if the interface is to be used by LNS based applications, e.g. a network management tool. This especially applies for older LNS versions up to 2.x. LNS 3.x version programs should use an Interface⁺, as these offer a better performance.

Interfaces running MIP firmware can be used for all other applications, e.g. the Easylon OPC Server M.

Transceiver

In their standard version Easylon Interfaces come with a free topology TP/FT (FTT-10) or FTX smart transceiver. Some interfaces are additionally available in standard variants with transformer coupled twisted pair transceiver (TP/ XF-78 or TP/XF-1250). Depending on the interface type OEM variants with EIA-485 or Direct Connect (DC) transceiver can be realized. Most of the EIA-485 interfaces provide galvanic isolation.

For details concerning available transceivers and drivers, please refer to the technical specifications of the different interface devices.

Tools for Development and Commissioning

Several tools are provided to support setting up the interfaces for operation. Problems eventually arising can thus easily be tracked down. Developers appreciate that Easylon Interfaces support a debug mode, helpful with testing new applications.

EasyCheck, for instance, is a small, versatile utility for setup and diagnosis of Easylon interfaces. Basic tests and configurations, such as setting LONWORKS address, mode and buffers, can easily be performed with EasyCheck. Communication tests can be performed by sending and receiving service pin messages. A higher level feature is scanning a domain for attached nodes. "Performance tests" will compare the speed of two interfaces. EasyCheck also shows the versions of all Easylon software installed on the PC.

Easylon IMAc, the Interface Management Center, offers everything you need for the configuration of LONWORKS interfaces. Not only PC cards and external LonTalk adapters can be handled but as well the Easylon Remote Network Interface (Easylon RNI) and the Easylon IP Interface, the software interface to the LON IP channel.

Both programs are included in the Easylon Interface delivery.

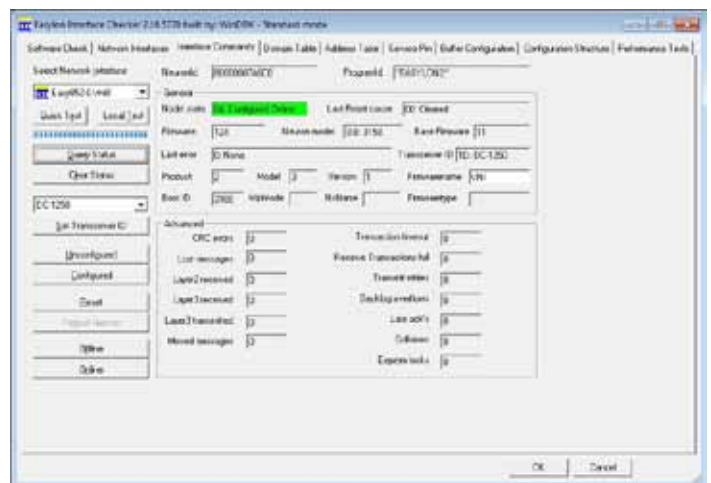

Remote Network Interface (RNI)

This software for remote access from a networked PC (LAN, Internet) via TCP/IP to the interface devices at a LONWORKS or CEA-709.1 compatible network is part of the scope of delivery of the Easylon interfaces. This is the smartest solution to realize network management tasks in a distant network from your office PC. You will find more details in the product description on page 11.

WLDV32.DLL

The WLDV32.DLL, being part of the Easylon interface scope of delivery, offers a 32 bit driver interface for Windows operating systems including CE. Nowadays the program package also covers 64 bit applications. The WLDV32.DLL is as well available separately for use with interfaces from other manufacturers.



Easylon® Interfaces at a Glance

LonTalk® and CEA-709.1 Adapters

		EASYLON INTERFACES ⁺						
								
		PCI Express	PCI, PCI-X	USB 2.0	IP Interface CEA-852	PC/104 ISA Bus	USB Socket USB 2.0	Serial Socket RS 232 TTL
Transceiver	TP/XF-78	-	+	-	-	+	-	-
	TP/XF-1250	-	+	-	-	+	-	-
	EIA-485	-	+	-	-	+	+	-
	FTT-10A	+	+	+	-	+	-	+
	DC-1250	-	+	-	-	+	+	-
	FTX Smart	-	-	-	-	+	+	+
	CEA-852	-	-	-	+	-	-	-
Firmware	MIP (MIP compatible)	-	-	-	-	+	+	+
	NSI (LNS compatible)	-	-	-	-	+	-	-
	VNI (LNS/MIP compatible)	+	+	+	+	-	-	-
Driver	DOS ⁴	-	-	-	-	+	-	+
	Windows 32 Bit: XP, Vista, 7, Server 2003, 2008, 2008 R2	+	+	+	+	+	+	+
	Windows 64 Bit: XP, Vista, 7, Server 2003, 2008, 2008 R2	+	+	+	+	+ ³	+	+
	Windows CE 3.0	-	-	-	-	+	+	+
	Windows CE 4.2, 5.0, 6.0	-	-	-	+	+	+	+
	Linux 2.4 / 2.6	+	+	+	+ ³	+	+	+
	Options	Extended temperature range	-	-	-	-	+	+
Coating	-	-	-	-	+	+	+	
Form factor modification	-	-	-	-	-	+	+	
Cap for FTT-10A	+	+	+	-	+	+	+	
Connector	Screw-plug terminal	-	-	-	-	-	-	-
	Weidmüller, 5.08 mm	+	+ ¹	+	-	-	-	-
	Phoenix, 3.81 mm	-	+ ¹	-	-	-	-	-
	D-type	-	+	-	-	-	-	-
	RJ45	+	+ ²	+	-	-	-	-
Pin connector	-	-	-	-	+	+	+	

1 not with EIA-485 variants

2 optional, on request instead of D-type

3 on request

4 unsupported

BUS INTERFACE	according to PCI Express Base Specification, r1.1; 1 lane (x1)	
NETWORK INTERFACE	according to ANSI/CEA-709.1	
Transceiver	FTT-10A	
Connectors	RJ-45 and 3 pin plug-screw (0.5–2.5 mm ²)	
Node-ID	in EEPROM	
DISPLAY & OPERATION		
LEDs	traffic, status and error	
Push button	service	
DIMENSIONS & ENVIRONMENTAL CHARACTERISTICS		
Dimensions	low profile PCI Express add-in card	
	70 x 131 [mm], w/o connectors	
slot bracket	low profile	80 mm
	standard height	121 mm
Temperature	operating	0 – +50 °C
	storage	-20 – +60 °C
Humidity	according DIN 40 040, class F, no condens.	
EMC	emission	EN 55 022 A/B
	immunity	EN 61 000-6-2
SOFTWARE		
Drivers for	Windows	XP, Vista, 7, Server 2003, 2008, 2008 R2, all for 32 and 64 bit systems
	Linux	Kernel 2.4, 2.6

EASYLON PCIe INTERFACE⁺

with standard height and low profile slot bracket

P.V10804

Easylon[®] PCIe Interface⁺

CEA-709.1 Control Network Interface for PCI-Express

- Real multi-client usage for up to 8 applications
- Full compatible VNI
- Parallel transactions in MIP mode
- Increased performance
- Supports usage in virtual machines
- RJ45 and plug-screw connector

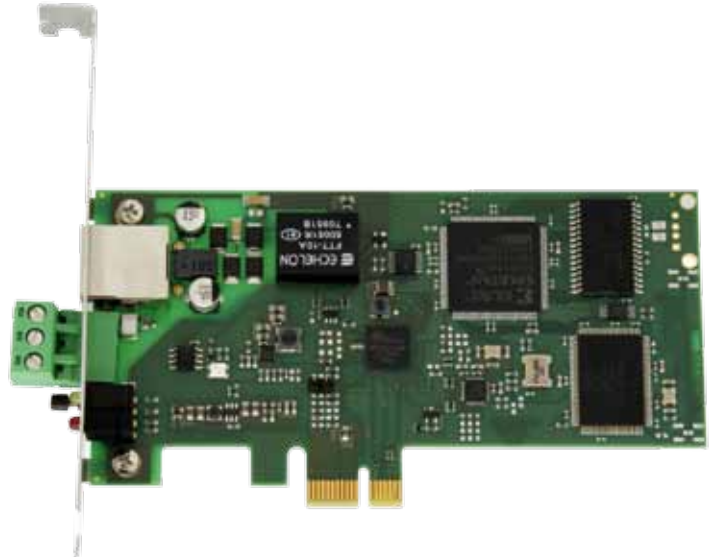

The Easylon PCIe Interface⁺ is a plug-in card according to CEA -709.1 to connect PC with PCI Express slots to CEA -709.1 compatible control networks.

As an Easylon Interface⁺ product it features several advantages. Simultaneous network access by up to eight PC applications is a major benefit. Both LNS and MIP based programs can be used. The Easylon PCIe Interface⁺ is compatible with other VNIs of other manufacturers and replaces traditional control network interfaces without modification of the applications. Furthermore this Easylon Interface is best suited for usage in virtual machines, e.g. VMware workstation.

Easylon interfaces⁺ are the preferred network adapters for the Easylon Analyzer in order to run a thorough network analysis.

The interface board is fitted with alternatively usable RJ45 and plug-screw connectors to connect to the network.

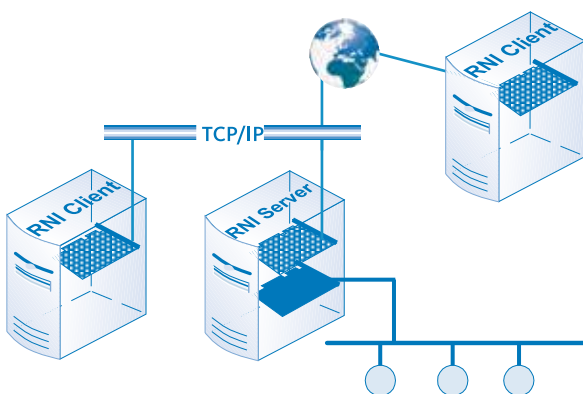

Easylon® PCI Interface⁺

CEA-709.1 Control Network Interface for PCI-Bus PC

- Real multi-client usage for up to 8 applications
- Full compatible VNI
- Parallel transactions in MIP mode
- Increased performance
- D-type and plug-screw connector



The Easylon PCI Interface⁺ is a plug-in card according to CEA-709.1 to connect a PCI-bus PC to CEA-709.1 compatible control networks.

As an Easylon Interface⁺ product it features several advantages. Simultaneous network access by up to eight PC applications is a major benefit. Both LNS and MIP based programs can be used. The Easylon PCI Interface⁺ is compatible with other VNIs of other manufacturers and replaces traditional control network interfaces without modification of the applications.

Easylon interfaces⁺ are the preferred network adapters for the Easylon Analyzer in order to run a thorough network analysis.

The interface board is fitted with alternatively usable D-type and plug-screw connectors to connect to the network. Customized versions can be fitted with RJ45 jacks instead of the D-type connector or the smaller Phoenix instead of Weidmüller connectors.

In addition to the usual TP/FT and TP/XF transceivers, a variant with EIA-485 transceiver is available.

PCI-BUS INTERFACE according to PCI-Bus standard 2.2; supports 3.3 and 5 V systems and PCI-X

NETWORK INTERFACE according to ANSI/CEA-709.1
Transceiver variants TPT/XF-78, TPT/XF-1250, FTT-10A, DC-1250, or EIA-485 (39 kbps)

Connectors 9 pin D-type and 2 pin plug-screw (0.5–2.5 mm²), not with EIA-485

options - RJ45 instead of D-type;
- Phoenix (3.81 mm) instead of Weidmüller (5.08 mm) connector

Node-ID in EEPROM

DISPLAY & OPERATION

LED traffic LED
Push button service

DIMENSIONS & ENVIRONMENTAL CHARACTERISTICS

Dimensions 105 x 130 [mm], incl. connectors
Temperature operating 0 – +50 °C
storage -20 – +60 °C
Humidity according DIN 40 040, Class F, no condens.
EMC emission EN 55 022 A/B
immunity EN 61 000-6-2

SOFTWARE

Drivers for Windows XP, Vista, 7, Server 2003, 2008, 2008 R2, all for 32 and 64 bit systems
Linux Kernel 2.4, 2.6
others on request

EASYLON PCI INTERFACE⁺

with transceiver type t

P.V1020t

Transceiver types: t = 1 = TP/XF-78 4 = FTT-10A
2 = TP/XF-1250 5 = DC-1250
3 = EIA-485

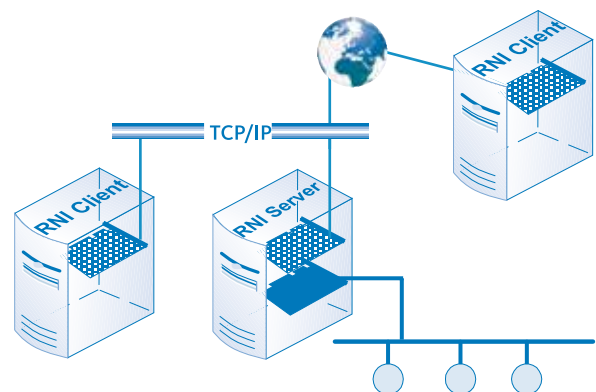

USB INTERFACE	according to high speed USB standard 2.0, compatible to full speed USB standard 1.1	
Connector	USB type B	
NETWORK INTERFACE	according to ANSI/CEA-709.1	
Transceiver variants	FTT-10A, variants on request	
Connectors	RJ45 and 3 pin plug-screw (0.5–2.5 mm ²)	
Node-ID	in EEPROM	
POWER SUPPLY		
Voltage	5 V, from USB port	
Input current	< 100 mA	
DISPLAY & OPERATION		
LEDs	service, status, error	
Push button	service	
DIMENSIONS & ENVIRONMENTAL CHARACTERISTICS		
Dimensions	128 x 71 x 23 [mm]	
Temperature	operating	0 – +50 °C
	storage	-20 – +60 °C
Humidity	class F, accord. DIN 40040, no condensation	
EMC	emission	EN 55022 A/B
	immunity	EN 61000-6-2
SOFTWARE		
Drivers for	Windows	XP, Vista, 7, Server 2003, 2008, 2008 R2, all for 32 and 64 bit systems
	Linux	Kernel 2.4, 2.6
	others	on request

EASYLON USB INTERFACE⁺

with FTT-10A transceiver

P.V10304

Easylon[®] USB Interface⁺

USB Interface to CEA-709.1 Networks

- Real multi-client capability on 8 channels
- Full compatible VNI
- Parallel transactions in MIP mode
- Increased performance
- Supports usage in virtual machines
- RJ45 and plug-screw connector
- USB 2.0 high speed 480 Mbps



The Easylon USB Interface⁺ is a handy sized USB module compliant to CEA-709.1 connecting a PC via USB to CEA-709.1 compatible control networks.

As an Easylon Interface⁺ product it features several advantages. Simultaneous network access by up to eight PC applications is a major benefit. Both LNS and MIP based programs can be used. The Easylon USB Interface⁺ is compatible with other VNIs of other manufacturers and replaces traditional control network interfaces without modification of the applications. Furthermore this Easylon Interface is best suited for usage in virtual machines, e.g. VMware workstation.

Easylon interfaces⁺ are the preferred network adapters for the Easylon Analyzer in order to run a thorough network analysis.

As flexible solution this adapter is suitable for both desktop PC and laptop. Being small, handy sized and without additional power pack it represents a favorably priced network access. With this plug & play device the laborious switchover of boards in case another computer requires the interface becomes obsolete.

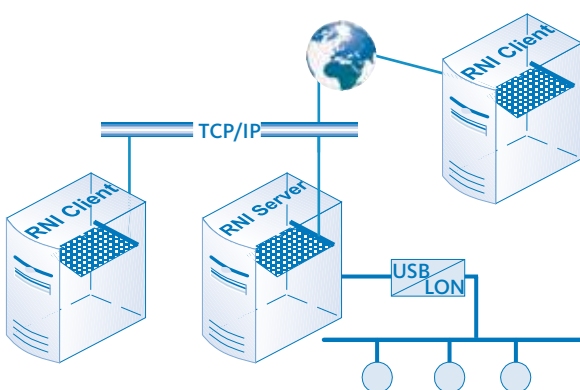

Easylon® IP Interface⁺

CEA-852 Compatible Network Interface

- LON over IP
- VNI and MIP interface
- Compatible with existing interfaces
- Parallel transactions in MIP mode
- Standard applications now with LON/IP
- Up to 8 clients



The Easylon IP Interface⁺ operates according to the EIA/CEA-852 standard. As software running on Windows PCs it provides a standard network interface to CEA-709.1 compatible networks.

Drivers for this interface provide the same functionality as other Easylon interfaces, thus enabling all applications operating with standard interfaces for LON over IP.

The Easylon IP Interface⁺ operates as a VNI interface. The drivers can also provide MIP interfaces. In an extended MIP mode 16 parallel transactions are possible for sending. Thereby performance is considerably increased. Up to eight client applications can use the interface simultaneously. Even old 16 bit applications can use this interface. Furthermore it can be used with the Easylon Analyzer software.

With the Easylon IP Interface⁺ applications become LON/IP enabled. This “LON over IP“ solution allows task processing on different computers integrated into local and global IP structures. Backbones of larger facilities can thus be realized via Ethernet.

Connecting to TP/FT LONWORKS networks requires a suitable LON/IP router, such as the Easylon Router⁺. The interface is, of course, compatible with all LON/IP routers.

Technical Features

Node-ID	in USB Dongle
Drivers for	Windows XP, Vista, 7, Server 2003, 2008, 2008 R2, all for 32 and 64 bit systems, CE 4.2, CE 5.0, CE 6.0
	Linux
	others on request

EASYLON IP INTERFACE⁺

CEA-852 compatible driver software

P.S20401

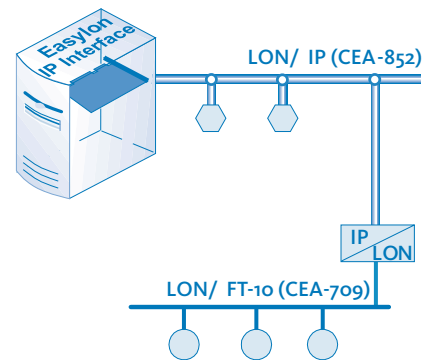

Info

STANDARDS AND NAMES

CEA-709	Communication protocol standard (ANSI/EIA), LONWORKS compatible; corresponding European standard: EN 14908
CEA-852	Standard for an Ethernet based communication protocol equivalent to LONWORKS (ANSI/EIA/CEA), corresponding European standard: EN14908 part 4
DIN EN 14908	“Open data communication in building automation, controls and building management”; European standard for LONWORKS equivalent communication protocol;
LON over IP	Usage of Ethernet / IP channel for LONWORKS protocol transfer.

EASYLON REMOTE NETWORK INTERFACE

Driver software

P.S20101

Software is included in the scope of delivery of Easylon interfaces. Separate orders are necessary only for interfaces of other manufacturers.

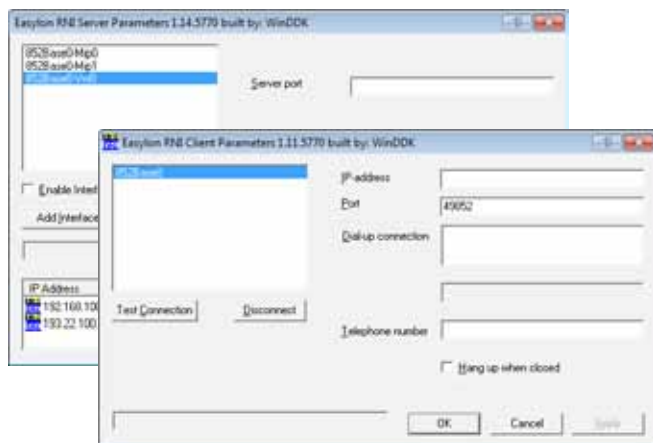
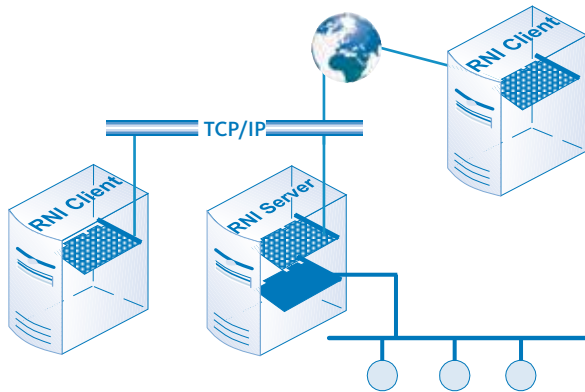

Easylon® Remote Network Interface

TCP/IP Access to Distant LONWORKS® Networks

- Software for remote access to LONWORKS networks
- Standard with all Easylon interfaces and Easylon Interfaces⁺
- Network management, status monitoring via standard PC communication

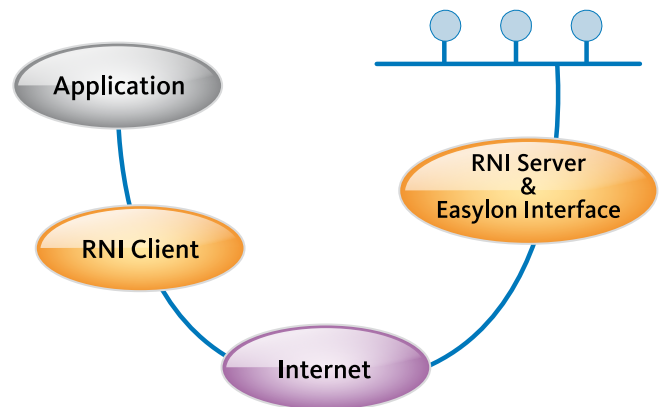

Similar to a server Easylon Remote Network Interface (RNI) enables access via a TCP/IP or dial-up connection to a PC–LONWORKS interface device from a remote PC. Target hardware on the network side can be a usual LonTalk® adapter in a PC as well as a standalone device such as the Easylon Router⁺. Thus remote access to LONWORKS data either via LAN or the internet is easily achieved.

Status monitoring, maintenance, download of modified programs – all this can be done from a remote PC with Internet connection using the RNI software. Requirements: a PC with Internet access, Easylon Interface and the RNI software at the LONWORKS network

Handling

The RNI driver can logically represent several LONWORKS interfaces. For each the IP address of the RNI server is entered and, if required, an additional phone number for the connection via the Windows dial-up network. Thus logical LONWORKS interfaces can be assigned to different remote servers. By selecting the desired LONWORKS interface in a LONWORKS tool the connection to a specific remote server can be established.

Existing systems can be upgraded easily and free of charge by installing the latest drivers and the RNI software. The RNI driver software required for the remote PC can also be installed quickly and subsequently you can handle network management or use data in visualization programs from your networked desktop. The RNI access method is standard with the Easylon Interfaces⁺ as well.

Easylon RNI is especially of interest for LONWORKS networks without LNS usage, which otherwise can hardly be accessed via TCP/IP.

Easylon RNI is available free of charge for all Easylon interfaces and at a minor license fee for PC-LONWORKS interfaces from other manufacturers.

Easylon® PC/104 Interface

LONWORKS® Interface Board for PC/104 Systems

- FTT-10A, FTX, TP/XF-78, TP/XF-1250, EIA-485 or other transceivers
- For networks with or without LNS
- Drivers for DOS, Windows and Linux
- Versions for extended temperature range
- EN 50155 and IEEE 1473-L compliant



The Easylon PC/104 Interface connects PC/104 systems to LONWORKS and other CEA-709.1 compatible control networks.

A variant with optically isolated EIA-485 transceiver is available further to the usual FTT-10A and TP/XF transceiver versions. The board can also be fitted with direct connect or FTX smart transceiver.

Interesting for use in embedded systems are OEM versions of this board, which can be adapted to the target system in moderate extent, e.g. adaptations concerning plug position and type can be realized.

This board, proven in industrial environment, is also available in versions with extended temperature range and customer specific coating. These versions are compliant to EN 50155, a standard used in railway technology.

PC/104 INTERFACE 8 bit data (I/O) according to personal computer bus standard IEEE P996 and PC/104 specification

I/O-addresses 4, setting by DIP switches
 Interrupts 3, 5, 7, 9, 10, 11, 12, 15 software selectable
 Coupling parallel, slave_A mode

NETWORK INTERFACE

Transceiver variants TPT/XF-78, TPT/XF-1250, FTT-10A, FTX, DC-1250 or EIA-485 (39 Kbps)

Connector pin connector
 Compatibility LonTalk, CEA-709.1

POWER SUPPLY

Voltage 5 V, from PC
 Power consumption 1.5 W, typically

DISPLAY & OPERATION

LED service LED
 option: LON traffic LED, signal externally usable
 Push button service

DIMENSIONS & ENVIRONMENTAL CHARACTERISTICS

Dimensions 90.2 x 95.9 [mm], incl. connectors
 Temperature operating 0 – +50 °C
 storage -20 – +60 °C
 extended range operating -40 – +85 °C
 storage -40 – +85 °C
 Humidity class F, accord. DIN 40 040, no condensation
 EMC emission EN 55 022 A/B
 immunity EN 61 000-6-2
 Compatibility EN 50155, IEEE 1473-L (version with ext. temp. range)

SOFTWARE

Drivers for Windows XP, Vista, 7, Server 2003, 2008, 2008 R2, all for 32 and 64 bit systems, CE 4.2, CE 5.0, CE 6.0
 Linux Kernel 2.4, 2.6
 others DOS, RT kernel, more on request
 Firmware NSI for LNS based applications
 MIP/P50 for networks without LNS applications

EASYLON PC/104 INTERFACE

with transceiver type t and

- MIP/P50 firmware

P.P1010t

- NSI firmware

P.P1011t

Transceiver types: t = 1 = TP/XF-78 4 = FTT-10a
 2 = TP/XF-1250 5 = DC-1250
 3 = EIA-485 6 = FTX

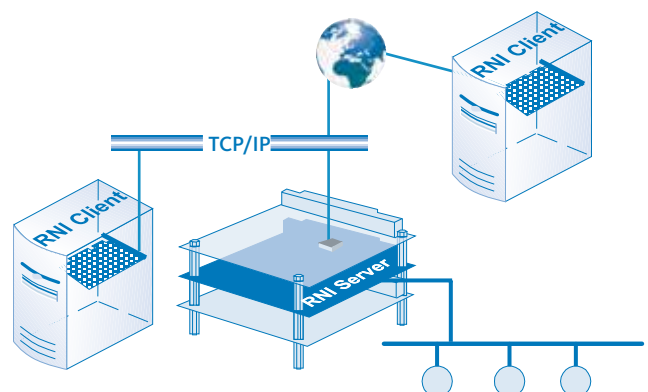

USB INTERFACE	acc. high speed USB standard 2.0, compatible to full speed USB standard 1.1
Connector	10 pin, accord. to ASUS board standard, OEM variants on request

NETWORK INTERFACE	
Transceiver variants	FTX, DC-1250 or EIA-485
Connector	3 pin, OEM variants on request
Compatibility	LonTalk, CEA-709.1

POWER SUPPLY	
Power Supply	from USB interface

DISPLAY & OPERATION	
LEDs	- service - status - error
Push button	- service

DIMENSIONS & ENVIRONMENTAL CHARACTERISTICS	
Dimension	37 x 66 [mm]
Temperature	operating 0 – +50 °C storage -20 – +70 °C
extended range	operating -40 – +85 °C storage -40 – +85 °C
Mounting	screw mounting

SOFTWARE	
Drivers for	Windows XP, Vista, 7, Server 2003, 2008, 2008 R2, all for 32 and 64 bit systems, CE 4.2, CE 5.0, CE 6.0
	Linux Kernel 2.4, 2.6
	others on request
Firmware	MIP/P2o, this module is not suited for LNS based applications.

EASYLON USB SOCKET INTERFACE

with transceiver type t and MIP/P2o firmware P.P1050t

Transceiver types: t = 3 = EIA-485 5 = DC-1250
6 = FTX

Easylon® USB Socket Interface

LONWORKS® Interface as Plug-In Module

- Integrable LONWORKS interface
- FTX, Direct Connect or EIA-485 transceiver
- Drivers for Windows and Linux
- Version with extended temperature range
- Economic OEM solution



The Easylon USB Socket Interface meets the requirements of device manufacturers for an integrated LONWORKS interface. Connected to the motherboard by USB the plug-in module with FTX transceiver realizes the connection to the LONWORKS network. Additional OEM variants can be realized with Direct Connect or EIA-485 transceiver.

Further to the opportunity to integrate a completed solution the details of the integration are crucial criteria. Location and design of the board connection, outlet of the LONWORKS interface from the housing, driver availability – these are design questions we are happy to resolve for this OEM module.

Easylon® Serial Socket Interface

Serial LONWORKS® Interface as Plug-In Module

- Integrable LONWORKS interface
- Reduced development effort
- LonTalk adapter or serial gateway
- Conexant compatible pin-out
- Version for extended temperature range
- Economic OEM solution



The Easylon Serial Socket Interface realizes a LONWORKS-serial connection as a socket module, to be integrated into OEM devices. The serial connection to the CPU board is designed according to the Conexant socket modem standard. Thus every board providing this connector becomes potentially LONWORKS enabled. Power supply uses this connector as well.

A FTX smart transceiver connects to the LONWORKS network. A variant with FTT-10A transceiver is also available. Service button and service LED are to be implemented on the main board. Firmware can be downloaded via the serial connection. MIP/P20 is used as firmware for the NEURON Chip. Thus, the module cannot be used with LNS based applications.

The Easylon Serial Socket Interface can be used as a **serial LonTalk adapter**. In this variant a serial protocol compatible to standard applications is implemented allowing for easy integration into existing applications.

In a second application variant the interface module operates as a **serial gateway**. A host application running on the module allows implementation of network variables – even more than the usual 62. Thus more data points than in simply NEURON based solutions can be used. The module's processor with large integrated memory enables implementation even of complex protocols.

As the serial interface offers the RTS and CTS signals, serial protocols with handshake can be implemented. Furthermore the connection of EIA-485 transceivers is facilitated.

As an OEM module a certain flexibility with respect to customer specific requirements has to be observed, e.g. with respect to the connector types or positions. Variants for extended temperature range and with coating are also available. Even for the realization of more thorough requirements we will be pleased to send you a specific offer.

NETWORK INTERFACE

CPU	NEURON 3120, 10–40 MHz
Transceiver variants	FTT-10A, FTX
Connector	pin connector
Service LED	on board or via Conexant connector
Service push button	via Conexant connector
Compatibility	LonTalk, CEA-709.1

CPU

Processor	8031 compatible
Clock	11.059 MHz
Memory	flash 64 kbytes, RAM 8 kbytes

SERIAL INTERFACE

Type	TTL, Conexant standard, RxD, TxD, RTS, CTS
Connector	pin connector
Transmission	up to 115.2 kBd

POWER SUPPLY

Voltage	5 V DC +- 5%, externally via Conexant socket
Power consumption	< 100 mA

DIMENSIONS & ENVIRONMENTAL CHARACTERISTICS

Dimension	65.6 x 26.6 [mm]	
Temperature	operating	0 – +50 °C
	storage	-20 – +70 °C
extended range	operating	-40 – +85 °C
	storage	-40 – +85 °C
Humidity	class F accord. DIN 40040, no condensation	

SOFTWARE

Drivers for	Windows	XP, Vista, 7, Server 2003, 2008, 2008 R2, all for 32 and 64 bit systems, CE 4.2, CE 5.0, CE 6.0	
	Linux	Kernel 2.4, 2.6	
	others	on request	
WLDV32	for Windows and Windows CE		
Firmware	MIP/P20, this module is not suited for LNS based applications.		

EASYLON SERIAL SOCKET INTERFACE

with transceiver type t and	
- MIP/P20 firmware as serial LonTalk adapter	P.P1070t
- firmware as serial gateway	P.P1072t

Transceiver types: t = 4 = FTT-10A 6 = FTX